

© International Baccalaureate Organization 2021

All rights reserved. No part of this product may be reproduced in any form or by any electronic or mechanical means, including information storage and retrieval systems, without the prior written permission from the IB. Additionally, the license tied with this product prohibits use of any selected files or extracts from this product. Use by third parties, including but not limited to publishers, private teachers, tutoring or study services, preparatory schools, vendors operating curriculum mapping services or teacher resource digital platforms and app developers, whether fee-covered or not, is prohibited and is a criminal offense.

More information on how to request written permission in the form of a license can be obtained from <https://ibo.org/become-an-ib-school/ib-publishing/licensing/applying-for-a-license/>.

© Organisation du Baccalauréat International 2021

Tous droits réservés. Aucune partie de ce produit ne peut être reproduite sous quelque forme ni par quelque moyen que ce soit, électronique ou mécanique, y compris des systèmes de stockage et de récupération d'informations, sans l'autorisation écrite préalable de l'IB. De plus, la licence associée à ce produit interdit toute utilisation de tout fichier ou extrait sélectionné dans ce produit. L'utilisation par des tiers, y compris, sans toutefois s'y limiter, des éditeurs, des professeurs particuliers, des services de tutorat ou d'aide aux études, des établissements de préparation à l'enseignement supérieur, des fournisseurs de services de planification des programmes d'études, des gestionnaires de plateformes pédagogiques en ligne, et des développeurs d'applications, moyennant paiement ou non, est interdite et constitue une infraction pénale.

Pour plus d'informations sur la procédure à suivre pour obtenir une autorisation écrite sous la forme d'une licence, rendez-vous à l'adresse <https://ibo.org/become-an-ib-school/ib-publishing/licensing/applying-for-a-license/>.

© Organización del Bachillerato Internacional, 2021

Todos los derechos reservados. No se podrá reproducir ninguna parte de este producto de ninguna forma ni por ningún medio electrónico o mecánico, incluidos los sistemas de almacenamiento y recuperación de información, sin la previa autorización por escrito del IB. Además, la licencia vinculada a este producto prohíbe el uso de todo archivo o fragmento seleccionado de este producto. El uso por parte de terceros —lo que incluye, a título enunciativo, editoriales, profesores particulares, servicios de apoyo académico o ayuda para el estudio, colegios preparatorios, desarrolladores de aplicaciones y entidades que presten servicios de planificación curricular u ofrezcan recursos para docentes mediante plataformas digitales—, ya sea incluido en tasas o no, está prohibido y constituye un delito.

En este enlace encontrará más información sobre cómo solicitar una autorización por escrito en forma de licencia: <https://ibo.org/become-an-ib-school/ib-publishing/licensing/applying-for-a-license/>.

Physics
Standard level
Paper 1

Monday 3 May 2021 (afternoon)

45 minutes

Instructions to candidates

- Do not open this examination paper until instructed to do so.
- Answer all the questions.
- For each question, choose the answer you consider to be the best and indicate your choice on the answer sheet provided.
- A clean copy of the **physics data booklet** is required for this paper.
- The maximum mark for this examination paper is **[30 marks]**.

1. A student measures the length l and width w of a rectangular table top.

What is the absolute uncertainty of the perimeter of the table top?

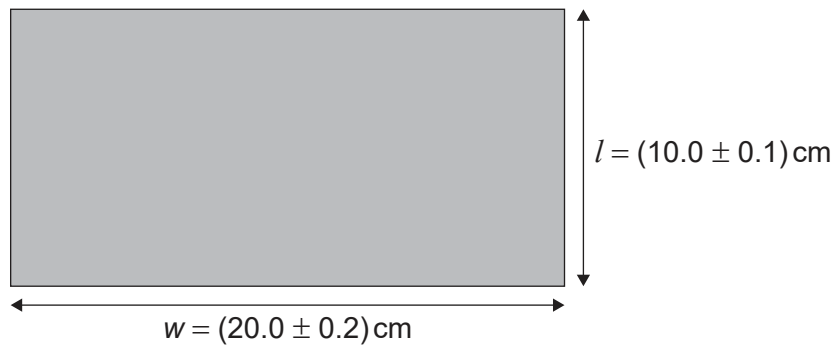

- A. 0.3 cm
B. 0.6 cm
C. 1.2 cm
D. 2.4 cm
2. What is the unit of power expressed in fundamental SI units?
- A. kg m s^{-3}
B. kg m s^{-1}
C. $\text{kg m}^2 \text{s}^{-1}$
D. $\text{kg m}^2 \text{s}^{-3}$

3. The minute hand of a clock hanging on a vertical wall has length $L = 30$ cm.

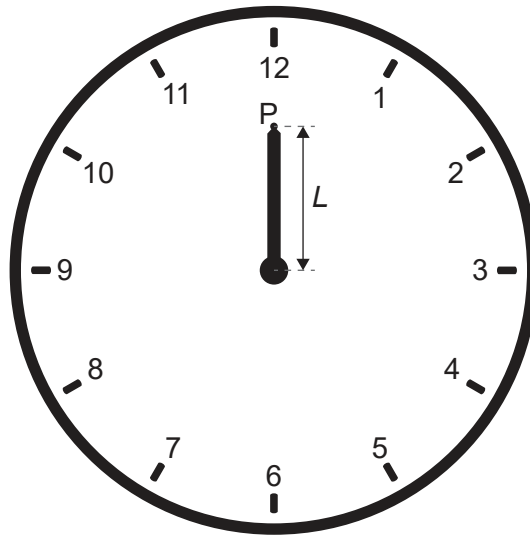

The minute hand is observed pointing at 12 and then again 30 minutes later when the minute hand is pointing at 6.

What is the average velocity and average speed of point P on the minute hand during this time interval?

	Average velocity	Average speed
A.	2 cm min^{-1} vertically downwards	$\pi \text{ cm min}^{-1}$
B.	2 cm min^{-1} vertically upwards	$\pi \text{ cm min}^{-1}$
C.	$2\pi \text{ cm min}^{-1}$ vertically downwards	$2\pi \text{ cm min}^{-1}$
D.	$2\pi \text{ cm min}^{-1}$ vertically upwards	$2\pi \text{ cm min}^{-1}$

4. A person is standing at rest on the ground and experiences a downward gravitational force W and an upward normal force from the ground N . Which, according to Newton's third law, is the force that together with W forms a force pair?
- The gravitational force W acting upwards on the ground.
 - The gravitational force W acting upwards on the person.
 - The normal force N acting upwards on the person.
 - The normal force N acting downwards on the ground.

Turn over

5. A person with a weight of 600 N stands on a scale in an elevator.

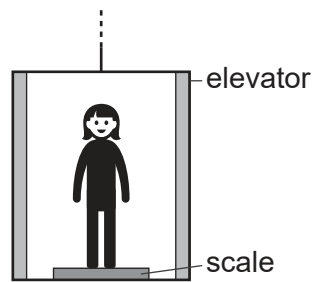

What is the acceleration of the elevator when the scale reads 900 N?

- A. 5.0 ms^{-2} downwards
 - B. 1.5 ms^{-2} downwards
 - C. 1.5 ms^{-2} upwards
 - D. 5.0 ms^{-2} upwards
6. Two identical boxes containing different masses are sliding with the same initial speed on the same horizontal surface. They both come to rest under the influence of the frictional force of the surface. How do the frictional force and acceleration of the boxes compare?

	Frictional force	Acceleration
A.	different	different
B.	different	equal
C.	equal	different
D.	equal	equal

7. Two identical blocks, each of mass m and speed v , travel towards each other on a frictionless surface.



The blocks undergo a head-on collision. What is definitely true **immediately** after the collision?

- A. The momentum of each block is zero.
 - B. The total momentum is zero.
 - C. The momentum of each block is $2mv$.
 - D. The total momentum is $2mv$.
8. A projectile is launched upwards at an angle θ to the horizontal with an initial momentum p_0 and an initial energy E_0 . Air resistance is negligible. What are the momentum and total energy of the projectile at the highest point of the motion?

	Momentum	Energy
A.	$< p_0$	E_0
B.	p_0	E_0
C.	p_0	$< E_0$
D.	$< p_0$	$< E_0$

Turn over

9. The graph shows the variation with distance of a horizontal force acting on an object. The object, initially at rest, moves horizontally through a distance of 50 m.

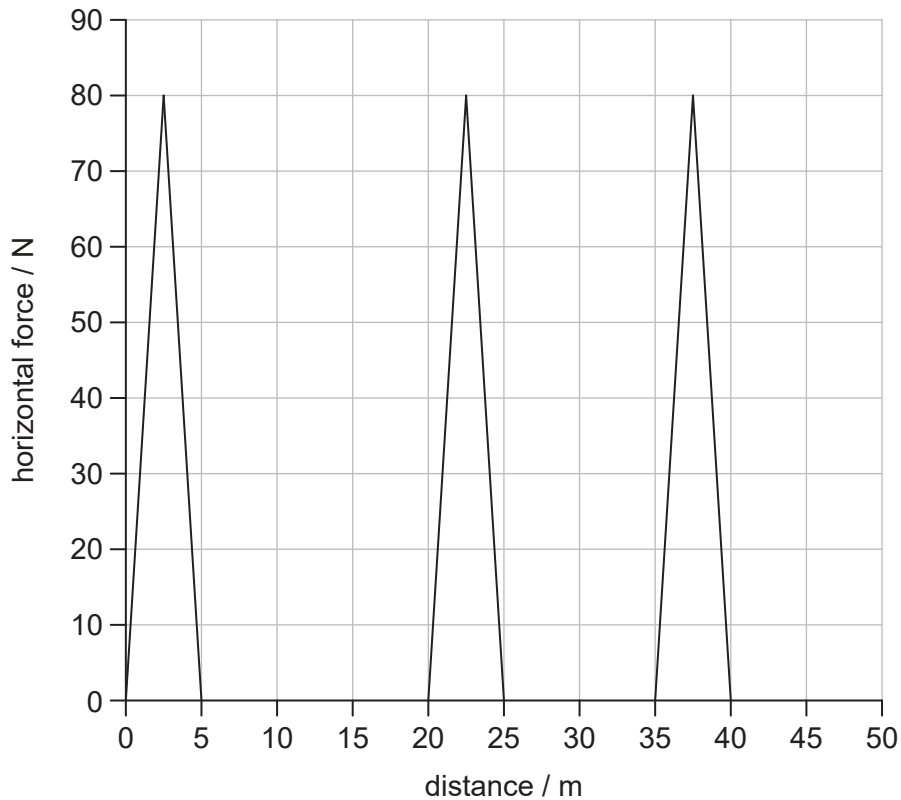

A constant frictional force of 2.0 N opposes the motion. What is the final kinetic energy of the object after it has moved 50 m?

- A. 100 J
 - B. 500 J
 - C. 600 J
 - D. 1100 J
10. A sample of oxygen gas with a volume of 3.0 m^3 is at 100°C . The gas is heated so that it expands at a constant pressure to a final volume of 6.0 m^3 . What is the final temperature of the gas?
- A. 750°C
 - B. 470°C
 - C. 370°C
 - D. 200°C

11. Two identical containers X and Y each contain an ideal gas. X has N molecules of gas at an absolute temperature of T and Y has $3N$ molecules of gas at an absolute temperature of $\frac{T}{2}$. What is the ratio of the pressures $\frac{P_Y}{P_X}$?

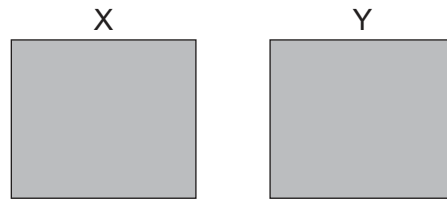

- A. $\frac{1}{6}$
B. $\frac{2}{3}$
C. $\frac{3}{2}$
D. 6
12. A piece of metal at a temperature of 100°C is dropped into an equal mass of water at a temperature of 15°C in a container of negligible mass. The specific heat capacity of water is four times that of the metal. What is the final temperature of the mixture?
- A. 83°C
B. 57°C
C. 45°C
D. 32°C
13. The bob of a pendulum has an initial displacement x_0 to the right. The bob is released and allowed to oscillate. The graph shows how the displacement varies with time. At which point is the velocity of the bob at its maximum magnitude directed towards the left?

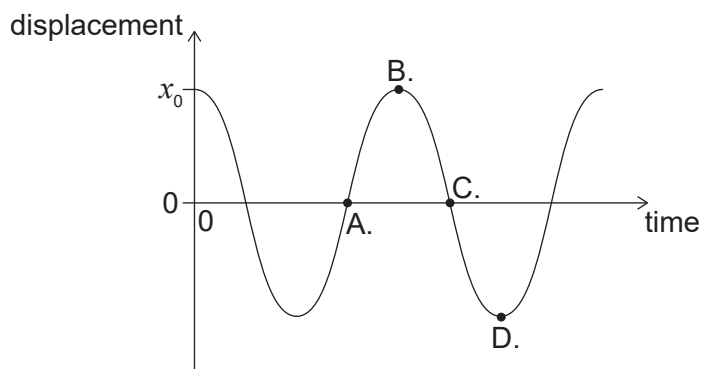

Turn over

14. Unpolarized light of intensity I_1 is incident on a polarizer. The light that passes through this polarizer then passes through a second polarizer.

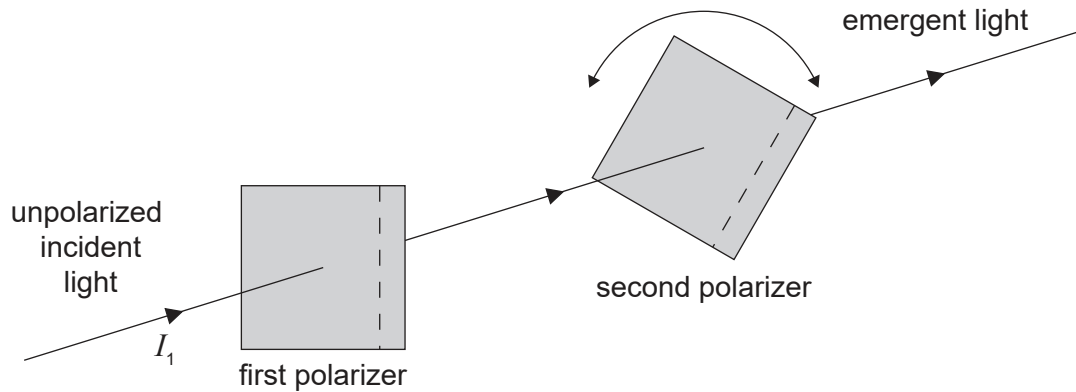

The second polarizer can be rotated to vary the intensity of the emergent light. What is the maximum value of the intensity emerging from the second polarizer?

- A. $\frac{I_1}{4}$
 B. $\frac{I_1}{2}$
 C. $\frac{2I_1}{3}$
 D. I_1
15. Two wave generators, placed at position P and position Q, produce water waves with a wavelength of 4.0 cm. Each generator, operating alone, will produce a wave oscillating with an amplitude of 3.0 cm at position R. PR is 42 cm and RQ is 60 cm.



Both wave generators now operate together in phase. What is the amplitude of the resulting wave at R?

- A. 9 cm
 B. 6 cm
 C. 3 cm
 D. zero

16. A glass block has a refractive index in air of n_g . The glass block is placed in two different liquids: liquid X with a refractive index of n_x and liquid Y with a refractive index of n_y .

In liquid X $\frac{n_g}{n_x} = 2$ and in liquid Y $\frac{n_g}{n_y} = 1.5$. What is $\frac{\text{speed of light in liquid X}}{\text{speed of light in liquid Y}}$?

- A. $\frac{2}{4}$
- B. $\frac{3}{4}$
- C. $\frac{4}{3}$
- D. 3

17. The frequency of the first harmonic in a pipe is measured. An adjustment is then made which causes the speed of sound in the pipe to increase. What is true for the frequency and the wavelength of the first harmonic when the speed of sound has increased?

	Frequency	Wavelength
A.	increase	unchanged
B.	unchanged	increase
C.	increase	increase
D.	unchanged	unchanged

18. The diagram shows two cylindrical wires, X and Y. Wire X has a length l , a diameter d , and a resistivity ρ . Wire Y has a length $2l$, a diameter of $\frac{d}{2}$ and a resistivity of $\frac{\rho}{2}$.

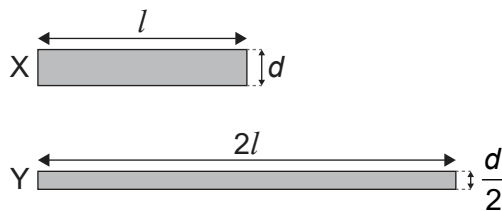

What is $\frac{\text{resistance of X}}{\text{resistance of Y}}$?

- A. 4
- B. 2
- C. 0.5
- D. 0.25

19. An ion moves in a circle in a uniform magnetic field. Which single change would increase the radius of the circular path?
- A. Decreasing the speed of the ion
 - B. Increasing the charge of the ion
 - C. Increasing the mass of the ion
 - D. Increasing the strength of the magnetic field

20. In the circuits shown, the cells have the same emf and zero internal resistance. All resistors are identical.

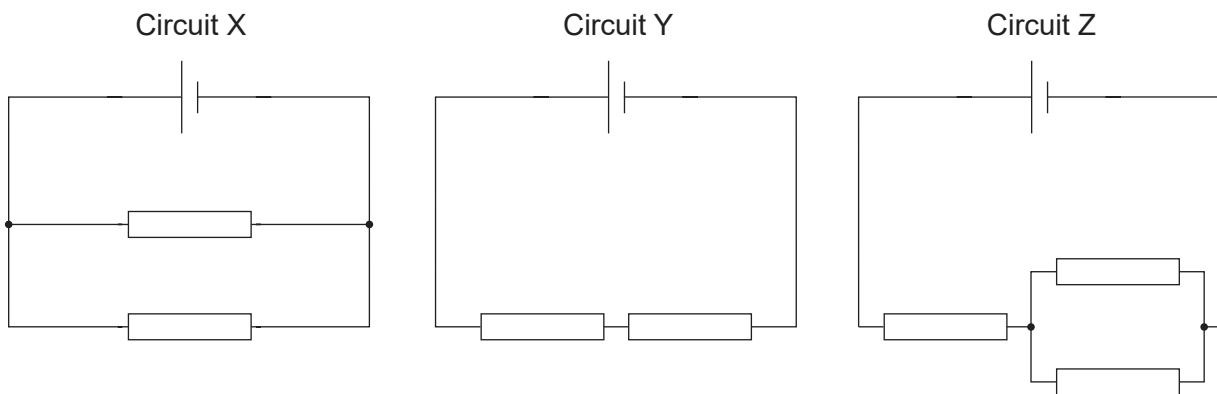

What is the order of increasing power dissipated in each circuit?

	Lowest → Highest power dissipated
A.	Y, Z, X
B.	X, Y, Z
C.	X, Z, Y
D.	Y, X, Z

21. Three identical resistors of resistance R are connected as shown to a battery with a potential difference of 12V and an internal resistance of $\frac{R}{2}$. A voltmeter is connected across one of the resistors.

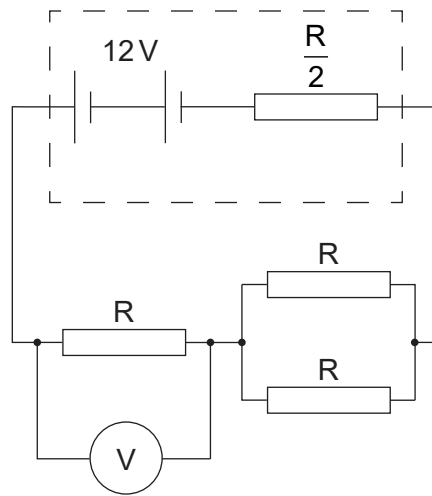

What is the reading on the voltmeter?

- A. 3V
 - B. 4V
 - C. 6V
 - D. 8V
22. Magnetic field lines are an example of
- A. a discovery that helps us understand magnetism.
 - B. a model to aid in visualization.
 - C. a pattern in data from experiments.
 - D. a theory to explain concepts in magnetism.

Turn over

23. An object moves in a circle of constant radius. Values of the centripetal force F are measured for different values of angular velocity ω . A graph is plotted with ω on the x -axis. Which quantity plotted on the y -axis will produce a straight-line graph?

- A. \sqrt{F}
- B. F
- C. F^2
- D. $\frac{1}{F}$

24. A sphere is suspended from the end of a string and rotates in a horizontal circle. Which free-body diagram, to the correct scale, shows the forces acting on the sphere?

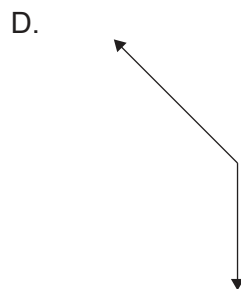
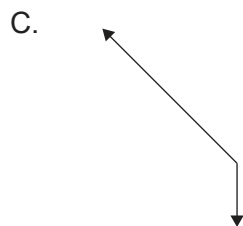
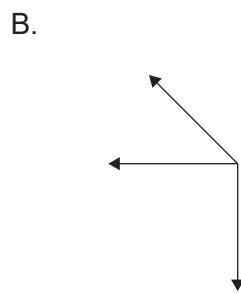
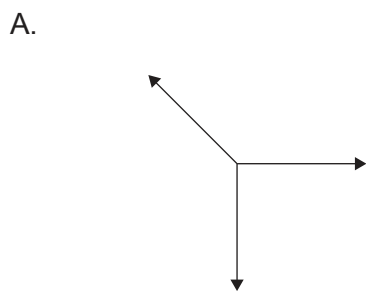
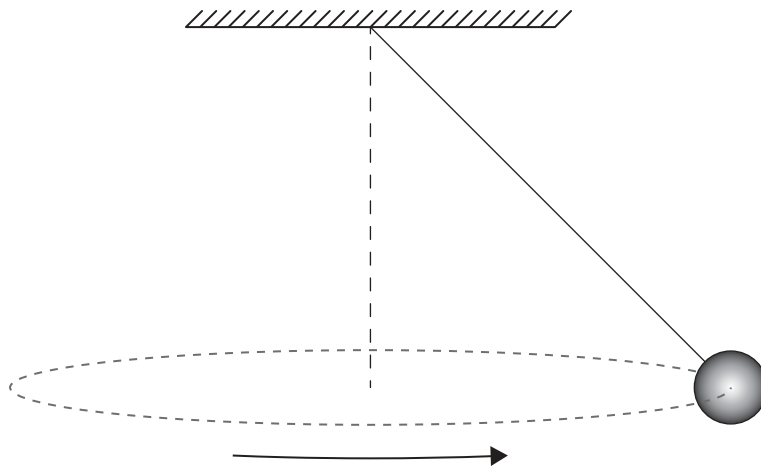

25. When a high-energy α -particle collides with a beryllium-9 (${}^9_4\text{Be}$) nucleus, a nucleus of carbon ($Z = 6$) may be produced. What are the products of this reaction?

	Product 1	Product 2
A.	carbon-12	proton
B.	carbon-12	neutron
C.	carbon-14	proton
D.	carbon-14	neutron

26. The diagram below shows four energy levels for the atoms of a gas. The diagram is drawn to scale. The wavelengths of the photons emitted by the energy transitions between levels are shown.

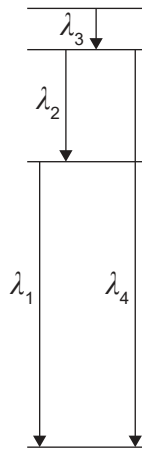

What are the wavelengths of spectral lines, emitted by the gas, in order of decreasing frequency?

- A. $\lambda_3, \lambda_2, \lambda_1, \lambda_4$
 - B. $\lambda_4, \lambda_1, \lambda_2, \lambda_3$
 - C. $\lambda_4, \lambda_3, \lambda_2, \lambda_1$
 - D. $\lambda_4, \lambda_2, \lambda_1, \lambda_3$
27. A kaon is made up of two quarks. What is the particle classification of a kaon?
- A. Exchange boson
 - B. Baryon
 - C. Lepton
 - D. Meson

Turn over

28. Consider the Feynman diagram below.

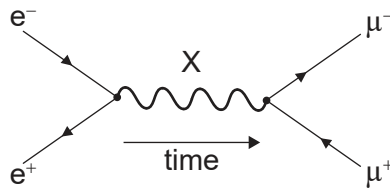

What is the exchange particle X?

- A. Lepton
 - B. Gluon
 - C. Meson
 - D. Photon
29. A black-body radiator emits a peak wavelength of λ_{max} and a maximum power of P_0 . The peak wavelength emitted by a second black-body radiator with the same surface area is $2 \lambda_{\text{max}}$. What is the total power of the second black-body radiator?
- A. $\frac{1}{16} P_0$
 - B. $\frac{1}{2} P_0$
 - C. $2 P_0$
 - D. $16 P_0$
30. What is the main role of carbon dioxide in the greenhouse effect?
- A. It absorbs incoming radiation from the Sun.
 - B. It absorbs outgoing radiation from the Earth.
 - C. It reflects incoming radiation from the Sun.
 - D. It reflects outgoing radiation from the Earth.

References:

© International Baccalaureate Organization 2021